

ECO-ARC 200

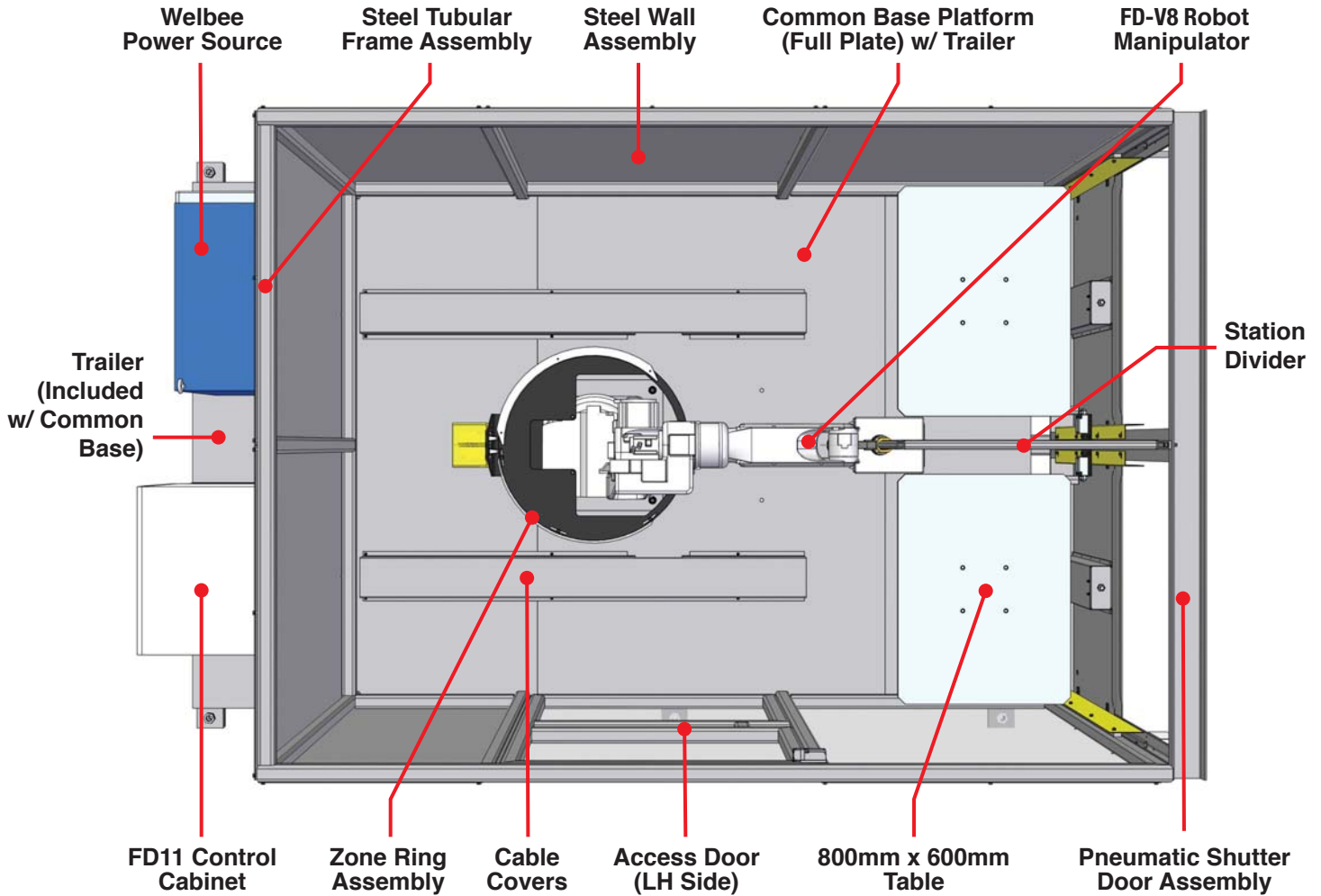

Standard Option:

ECO-ARC 200 – 2 stationary tables with standard robot manipulator (FD-V8)

- Tabletop Dimensions: 800mm x 600mm
- Weight – Approx. 2000kg

Details:

- Pneumatic shutter doors
- Zone Ring for station designation
- Standard fork lift pockets in base for easy movement
- Steel wall station divider

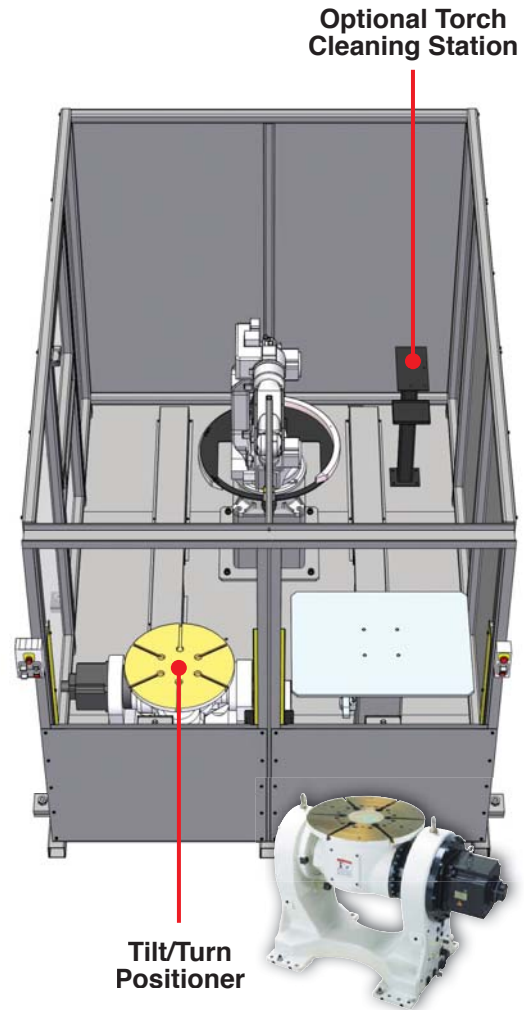
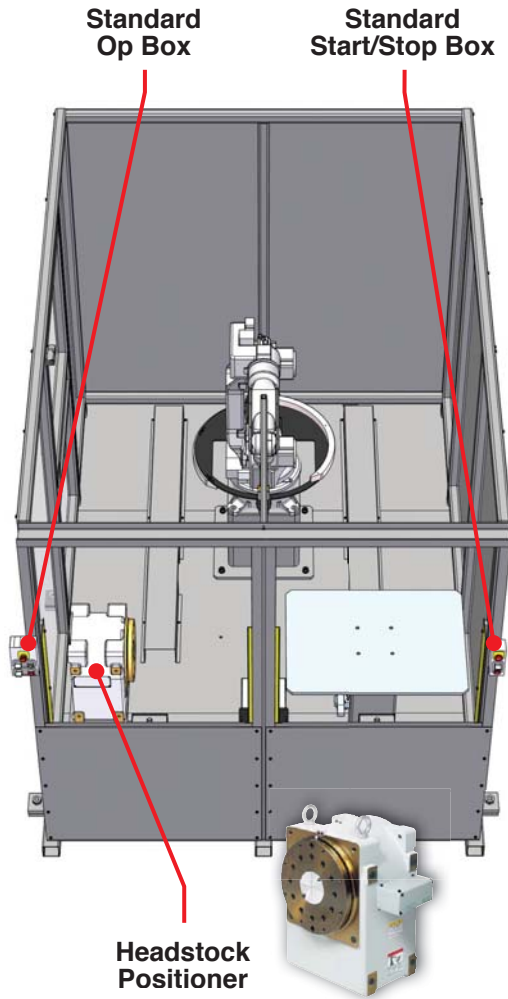

Specifications:

Footprint Dimensions:

- Width: 2194mm (86.4")
- Height: 2158mm (85.0")
- Depth: 3430mm (135.0")

Manipulator Types:

- FD-V8
- FD-B6

Cell Options:

- 2 Stationary Tables
- Positioner/Table
- 2 Positioners

Headstock Options:

- A2PB-250
- A2PB-500
- A2PB-1000

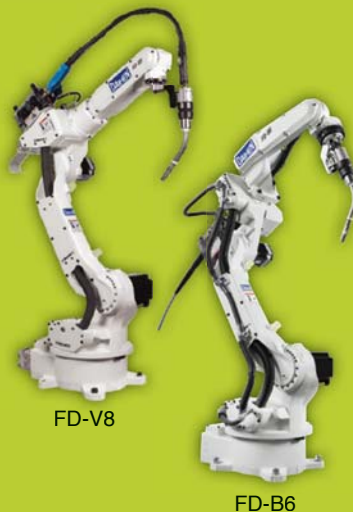

Tilt/Turn Options:

- A2PF-300
- A2PF-500
- A2PF-1000

Available I/O Slots: 28 Inputs/26 Outputs
(Additional Power Supply needed for Outputs)

Other Options:

- Basic Base Design (ECO-ARC 200B)
- Safety Fencing on Floor
- Safety Fencing on Full Base
- Access Door on RH Side
- Manual Sliding Door Assembly
- Station Lighting
- Torch Cleaning Station
- Fixture Mounting Pattern in Table Top
- Extended I/O