

SERVO-ARC 600

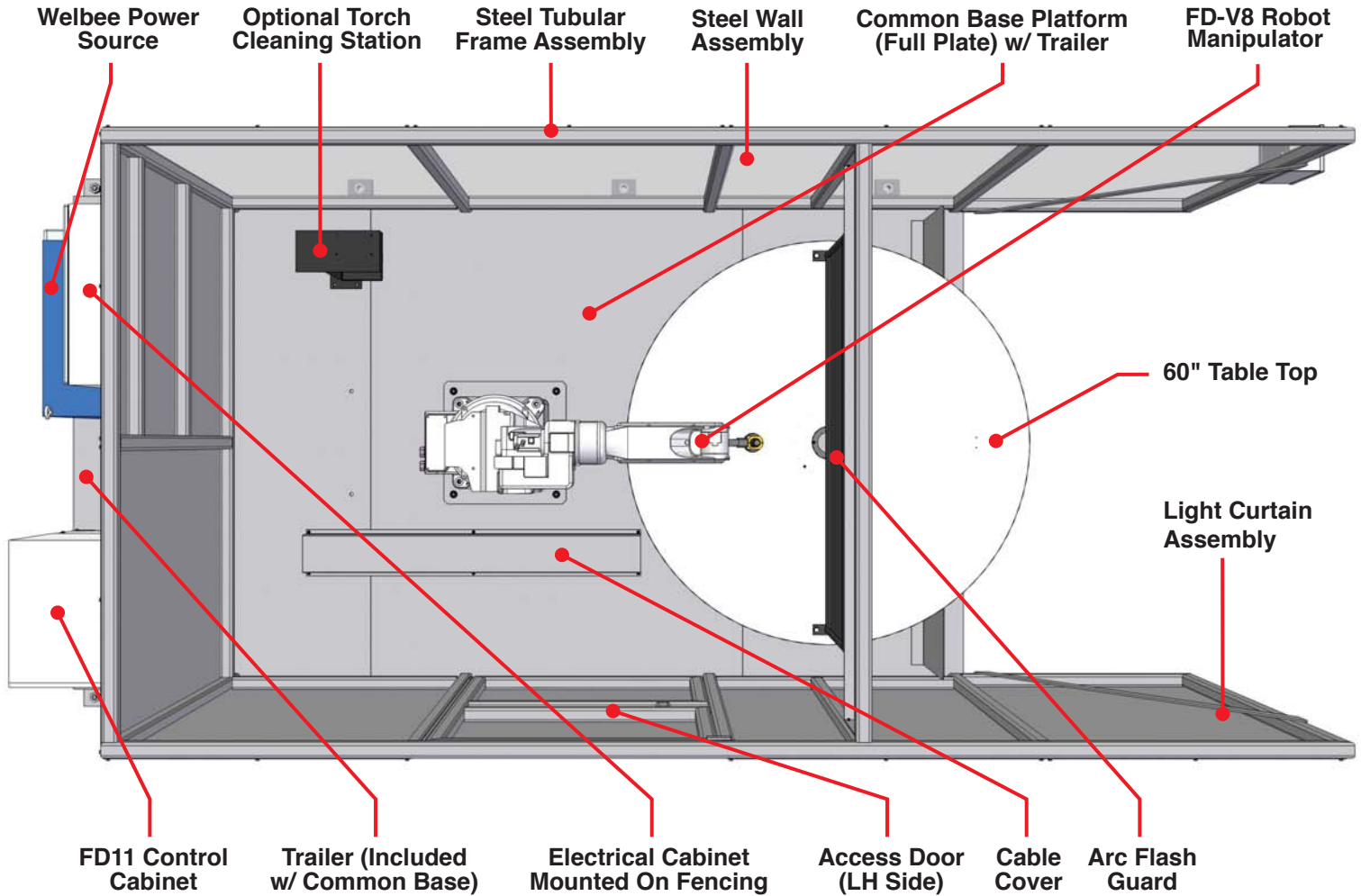

Standard Option:

SERVO-ARC 600 – 60" servo-driven indexing table

- Weight – Approx. 3000kg
- Standard fork lift pockets

Details:

- 1.2kW Servo-motor, RV-40E Gearbox
- Omron 1495mm Light Curtains
- Omron Switch/Two Actuators for station designation
- 3" through hole diameter in table top
- Index Speed (180°) - 4.2 seconds
- Work Capacity – 250kg/side

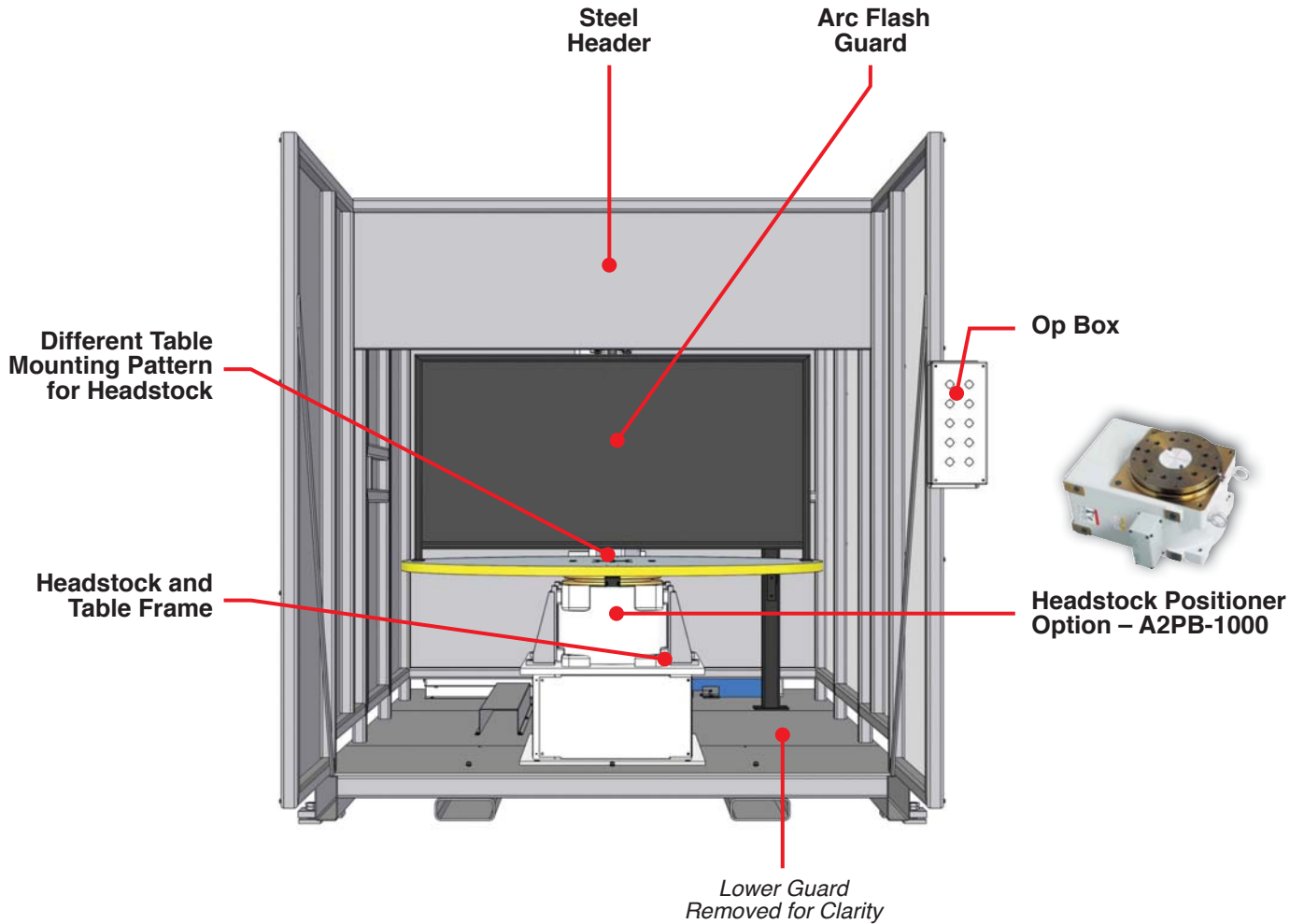

Specifications:

Footprint Dimensions:

Width: 2200mm (86.6")
 Height: 2235mm (88.0")
 Depth: 4584mm (180.5")

Manipulator Types:

- FD-V8
- FD-B6



Available I/O Slots:

23 Inputs/24 Outputs
 (Additional Power Supply needed for Outputs)

Additional Options:

- A2PB-1000 Headstock instead of servo-table
- Fixture mounting pattern in table top
- Torch cleaning station
- Station Lighting
- Access door on RH side
- Safety Fence on Full Base
- 48" Table Top
- Basic Layout (SERVO-ARC 600B)
- Extended I/O